



PLATFORM 13 SERIES

QUICK START GUIDE*

* ACTIVATION OF THE SYSTEM (charging and installation of the battery) for the CYCLIST WHEN GROUPSET IS PAIRED AND ASSEMBLED

IT Questo documento si affianca e non sostituisce gli User Manual dei componenti che devono essere letti e compresi prima di utilizzare questo prodotto, la cui mancata osservanza potrebbe causare incidenti, lesioni fisiche o morte.

EN This document supplements and does not replace the User Manuals of the components, which must be read and understood before using this product. Failure to observe them could result in accidents, personal injury or death.

ES Este documento acompaña y no reemplaza el Manual del usuario del componente que debe leerse y entenderse antes de usar este producto; el incumplimiento de estas instrucciones podría provocar accidentes, lesiones físicas o la muerte.

DE Dieses Dokument ersetzt nicht die Bedienungsanleitung der Komponente, die vor der Verwendung dieses Produktes gelesen und verstanden werden muss deren Nichtbeachtung zu Unfällen, zu Körperverletzungen oder zum Tod führen und könnte, sondern ergänzt diese.

FR Ce document accompagne et ne remplace pas le manuel d'utilisation du composant, qui doit être lu et compris avant d'utiliser ce produit. Le non-respect de ce manuel peut entraîner un accident, des blessures voire la mort.

JP この説明書は構成部品のユーザー・マニュアルを補完するもので、その代わりになるものではありません。この製品を使用する前には、必ずユーザー・マニュアルをよく読み、内容を理解してください。それを怠ると、事故や身体損傷、死亡の原因になる場合があります。

LEGENDA

	IT	EN	ES	DE	FR	JP
	Premere	Press	Presión	Druck	Appui	押す
	Pressione veloce	Single press	Presión rápida	Schneller Druck	Appui rapide	短く押す
	Lampeggio veloce	Fast blinking	Parpadeo rápido	Schnelles Blinken	Clignotement rapide	速い点滅
	Lampeggio lento	Slow blinking	Parpadeo lento	Langsames Blinken	Clignotement lent	遅い点滅
	Tempo limite	Time limit	Tiempo límite	Zeitlimit	Limite de temps	消えるまでの時間
	Fisso	Constant	Fijo	Fest	Fixe	固定
	Spento	Off	Apagado	Aus	Éteint	消灯

GROUPSET ALREADY PAIRED, BATTERY TO BE INSTALLED

If the batteries are already installed and charged, please go to Step 3.

STEP 1 CHARGE YOUR BATTERY

Use standard USB (5 Volt - 2 Ampere)



STEP 2 WAKE THE SHIFTER UP INSERT AND LOCK THE BATTERY

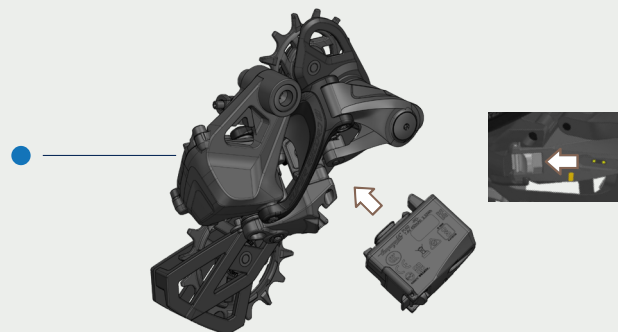

STEP 3 WAKE THE SYSTEM UP

Just shake your bike, and press few time the shifting levers. It can take up to 30s before rear derailleur moves.

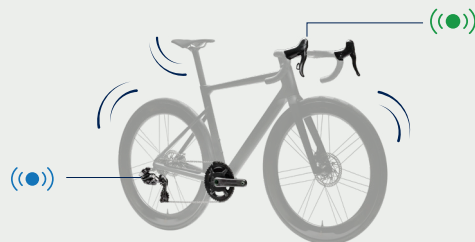

STEP 4 WHEN THE LEDs TURN OFF, THE SYSTEM IS OPERATIONAL

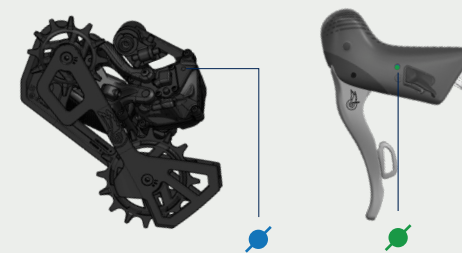

»»» READY TO RIDE «««

GROUPSET PAIRED AND ASSEMBLED, BATTERY ALREADY INSTALLED

Just shake your bike, press one shifting lever and check the LEDs (can take up to 30s)

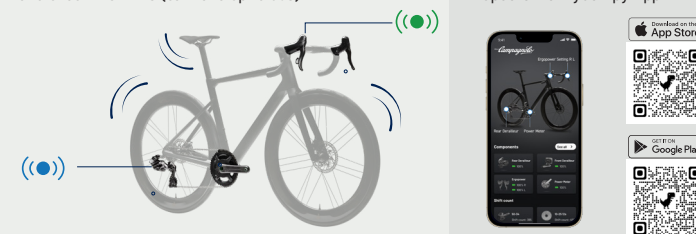

WHEN THE LEDs TURN OFF, THE SYSTEM IS OPERATIONAL

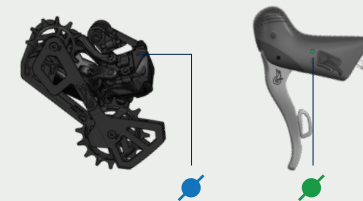

»»» READY TO RIDE «««

BATTERY LEVEL

Press the mode button

Battery level

- 100% - 50%
- 50% - 10%
- 10% - 0%

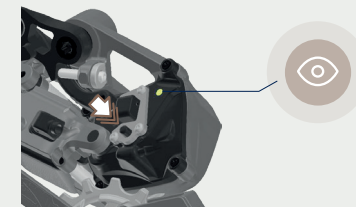



PLATFORM 13 SERIES

QUICK START GUIDE*

* GROUPSET SETUP PROCEDURE
For qualified mechanics only

GROUPSET TO BE PAIRED, BATTERY TO BE INSTALLED

STEP 1 CHARGE YOUR BATTERY

Use standard USB (5 Volt - 2 Ampere)



STEP 2 WAKE THE SHIFTER UP

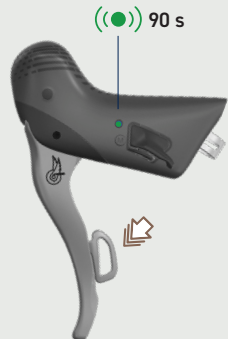

STEP 3 INSERT AND LOCK THE BATTERY

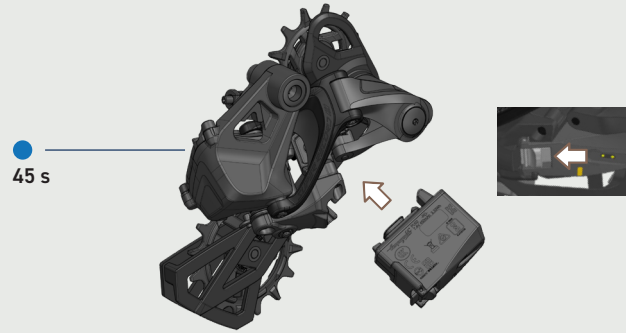

PAIR THE SYSTEM

Just shake your bike, and press few time the shifting levers.
It can take up to 30s before rear derailleur moves.

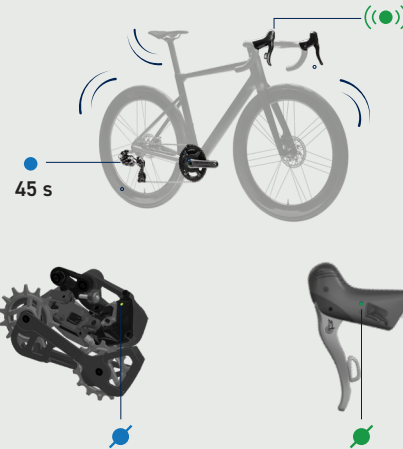

In case the system isn't operational for a failed pairing, please refer to the procedure:
Erasing the Bluetooth memory of the components.
In this case you need to erase the memory of the rear derailleur and right Ergopower only

READY TO SET

STEP 4 REAR DERAILLEUR SETTING

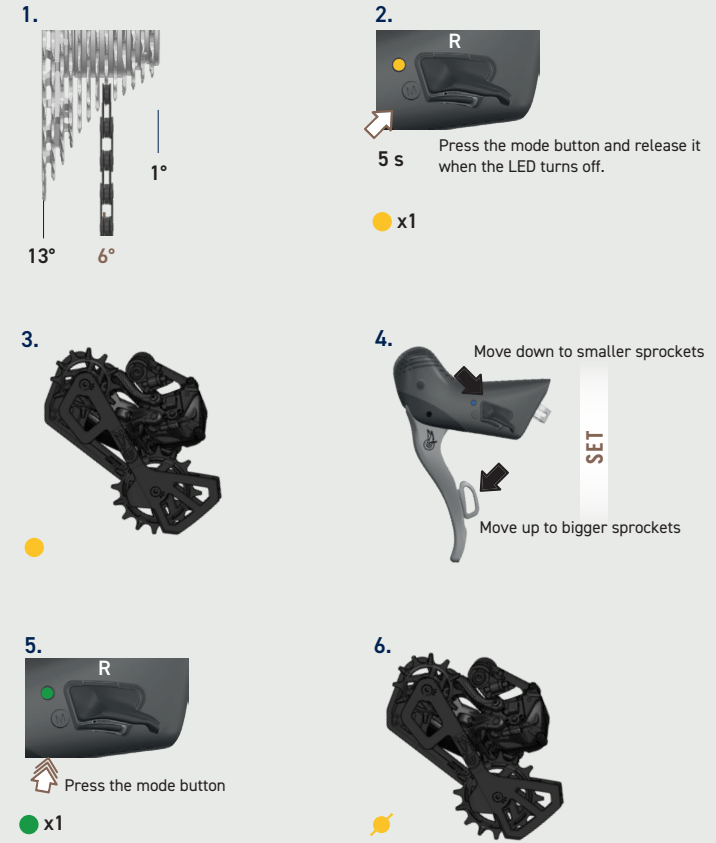

REAR DERAILLEUR SET

⚠ Check the inner and outer travel limit screws and the pulley adjustment screws!

Campagnolo S.r.l. reserves to modify the content of this document without notice.
The updated version will always be available at www.campagnolo.com

DISCOVER MORE

Join us to be part of our community

- facebook.com/CampagnoloOfficial
- twitter.com/campagnolosrl
- instagram.com/campagnolosrl
- youtube.com/user/CampagnoloSrl

